

U55-6

For Earth, For Life
Kubota

Kubota Mini Excavator



Experience the Premium

High Grade Mini Excavator

U55-6

Combining the power for demanding jobs and the versatility to work in any condition, the Kubota U55-6 is ready to take on any challenge.

This advanced 5.5 tonne machine is designed with excellent stability to work efficiently even where space is confined. With upgraded digging and lifting power and smoother travel performance, this Kubota truly has it all.





Greater Operator Comfort

On the U55-6, your comfort truly comes first. The wider operator space is realized by an enlarged cabin. The new digital panel provides advanced and convenient operation. Operability is greatly enhanced with more easy-to-use features than ever before.

Wider Operator Space

The enlarged cabin provides wider operator space which increases operator comfort. Especially, the wider foot space reduces operator stress during work.

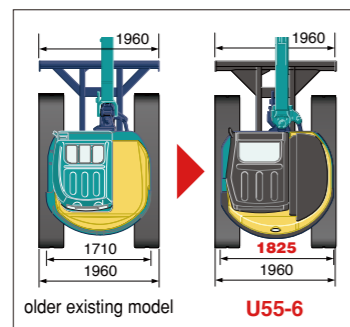

ROPS/FOPS Cabin

Stress analyses on ROPS (Roll Over Protective Structure) and FOPS (Falling Object Protective Structure) reveal that the following requirements are met:
 •Required energy absorption capability
 •Required load carrying capability
 •Ensures operator safe zone



Comfortable reclining seat

Drink holder



Backup power supply

12V "Cigarette lighter" sock provides back up power



Digital Panel



Following the excellence of Kubota's Intelligent Control System, the new digital panel puts convenience at the operator's fingertips. Featuring easier button operation, the user-friendly digital panel is positioned to the front right corner of the operator. This operator-facing wider display greatly improves visibility. With easier access, simpler settings, easy-to-read indicators and alerts, you'll always be aware of the excavator's functioning status.

- A User setting switch
- B Crane mode selector
※Crane mode only

- C Information switch
- D Display selector switch



Standard mode



Service interval information



Warning mode

Operation History Record

Operation history is automatically recorded on the U55-6. You can trace back up to 90 days of the machine's usage dates by simply checking the built-in calendar.

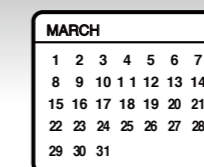

Operation History Record

Superior Performance

Upgraded engine and hydraulic system maximizes efficiency for every action such as digging, leveling, lifting and traveling.

3-pump Load Sensing Hydraulic System

Kubota's improved 3-pump load sensing hydraulic system ensures smoother operation, regardless of load size. It allows hydraulic oil to flow according to the specific range of the operator's lever motion. The result is greater fuel economy and smoother traveling.

3-pump load sensing system

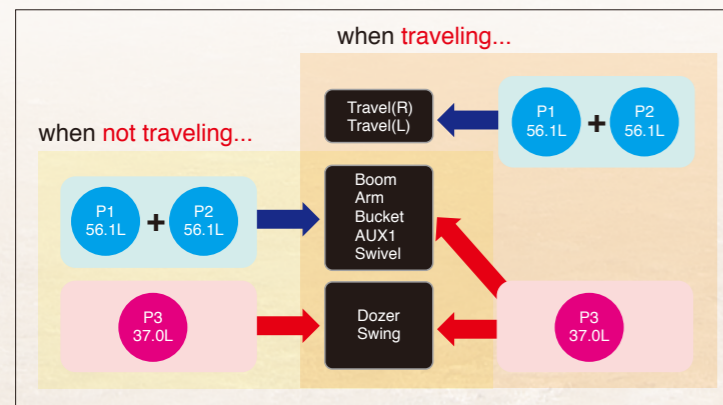

Shorter distance between dozer and bucket teeth

Distance between dozer and bucket teeth is shortened. It protects against the exfoliation of asphalt and it improves working efficiency.

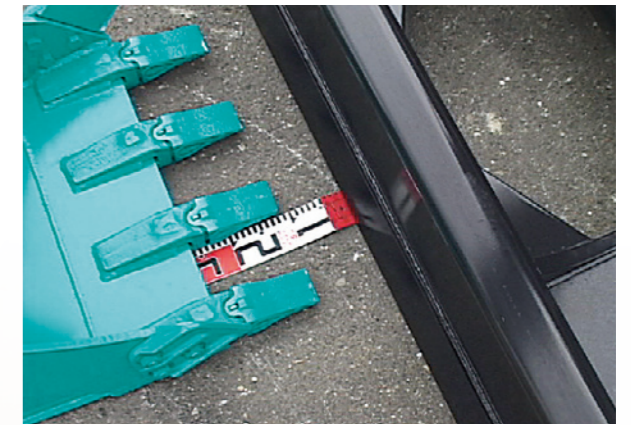

Built-in type working light
Guarded from damage

Boom cylinder cover

Fully Hydraulic Pilot Control Lever

Applications ranging from travel, swivel and fine maneuvering to dozer operations are realized by light, simple movements of the hydraulic pilot control lever.

2 speed travel with Auto-shift

The auto-shift system enables automatic travel shifting from high to low depending on traction effort and terrain. The combination with the 2-speed travel button mounted on the dozer lever trigger, allows for smoother operations when dozing and turning.



Third line hydraulic return

When working with one-way hydraulic attachment, such as a breaker, the standard third-line hydraulic return system allows oil to flow directly back to the tank without running through control valves. This contributes to less oil contamination, reduced back pressure, and greater oil flow efficiency.

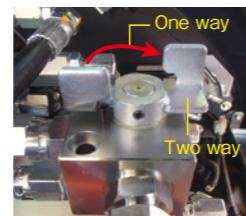

Parking Brake

For safety purposes, the parking brake is a standard feature. It improves safety during transportation on a truck or parking on a slope.

Increased digging and boom lifting force

Boom lifting : 138.6%
Bucket breakout : 116.0%
*compared to the older existing model

X-shaped and Slanted
Track frame
Designed to reduce soil
accumulation on the frame

Separated dozer hose
Independent hoses for easier maintenance
and replacement

Newly designed reinforced bucket
The reinforced bottom combined with
a new special design reduces mud
adhesion.



High Performance Engine & Easy Maintenance

New powerful direct injection engine provides high performance for every job. The combination of a newly designed engine with fully-opening hoods allows for easy maintenance.

●Kubota original DI Engine

The U55-6 is powered by Kubota's impressive 47.6Hp direct injection engine. Engineered with the power to maximize digging and lifting performance, it also delivers minimized noise and vibration.



V2607-DI-E3-BH-5

●Auto Idling system

Kubota's Auto Idle system helps save up to 10% fuel. When the control levers are in neutral for more than four seconds, the engine idles automatically. Move any control lever and the engine immediately engages. This innovative feature reduces noise, exhaust emissions and running costs.

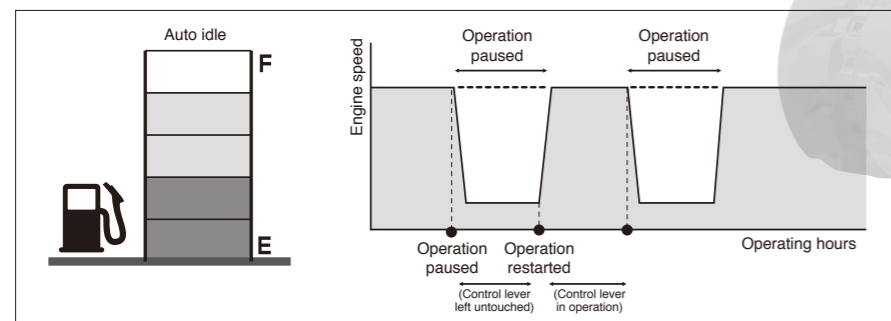

●One-sided Engine Maintenance

Kubota has made routine maintenance extremely simple by consolidating primary engine components onto one side for easier access. Engine and other vital components can be inspected quickly and easily.

●Fully-opening Hoods

The two fully-opening hoods - the right side hood and the rear hood - provide easy access to the fuel tank and the hydraulic system to make inspection and maintenance much easier.

●Reclining oil cooler

Simply by removing two bolts, the oil cooler comes down and forward to make it easier to clean between the oil cooler and radiator.

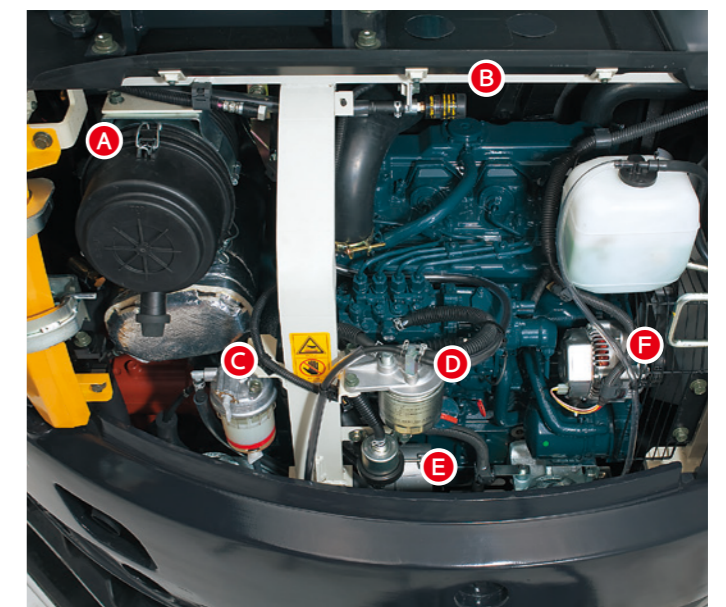

- A Air Cleaner
- B Air Cleaner Indicator
- C Water separator
- D Fuel filter
- E Starter Motor
- F Alternator



High Usability

Tight tail design and other user - friendly functions provide comfort when operating.



●Tight tail

Tight tail design allows for safe, confident operation in a tight work area.



●Excellent smooth controllability

The combination of the pilot control lever and the ergonomically arranged operating control system supports smooth operation.



●Control pattern change (4 patterns)

Control pattern can be easily changed.



●Refueling alarm

Simply press the fueling alarm button when refueling to prevent spillage. At first there is an intermittent "beep-beep" sound which gradually grows more rapid to become a continuous warning when the fuel tank is full.



●Tool box

The tool box is a standard feature located within the right-side hood to the front.



Kubota U55-6 Active in Singapore

Kubota Mini Excavators are used all over the world in a variety of construction applications including road-building, municipal works, pipe-laying, landscaping, water conservation projects and more. Kubota's world class features enable easy and efficient operation in the toughest conditions on all construction site making these Mini Excavators ready to take on any challenges.



Specifications

Model		U55-6	
Bucket capacity	m ³	0.16	
Std. bucket width: (with/without side teeth)	mm	650/600	
Machine weight	Kg	5,262	
Operating weight (Including operator weight: 75kg)	Kg	5,337	
Dimensions (In transport condition)	Overall length	mm	5,500
	Overall height	mm	2540
	Overall width	mm	1,960
	Min. ground clearance	mm	310
Engine	Model	Kubota V2607-DI-E3-BH-5	
	Total displacement	cc	2,615
	Rated output	kW (HP)	35.5 (47.6)
Performance	Max. digging height	mm	5,665
	Max. dumping height	mm	4,005
	Max. digging depth	mm	3,630
	Max. vertical wall digging depth	mm	2,830
	Max. digging radius	mm	6,100
	Boom swing (right/left)	mm	70/55
	Min. turning radius (with swing)	mm	2,460 (2,020)
	Min. tail turning radius	mm	1040
Max. breakout force (bucket)	kN (kgf)	42.3 (4,315)	
Track type	Steel		
Track width	mm	400	
Travel section	Crawler length	mm	2,500
	Tumbler distance	mm	1,990
	Travel speed (1st/2nd gear)	km/h	2.8/4.9
	Max. climbing angle	deg	30
Swivelling speed	rpm	9.3	
Dozer	Dozer width	mm	1,960
	Dozer height	mm	405
	Lift height (GL up/down)	mm	440/410
Hydraulic pump type	Variable pump×2 + Gear pump×1		
Swivel motor type	Hydraulic piston motor		
Travel motor type	Hydraulic piston motor: 2F		
Fuel tank capacity	L	68	

Working Range of U55-6

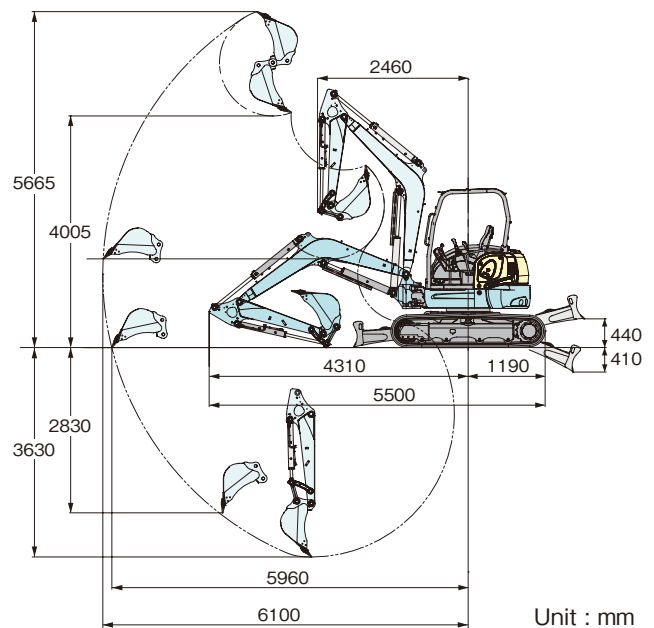
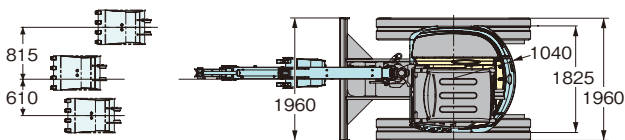

Unit : mm



陸機械私人有限公司
LAND EQUIPMENT PTE LTD

32 JOO KOON ROAD SINGAPORE 628985
TEL: (65) 6862-5223 FAX: (65) 6861-5223
E-Mail: sales@land-equipment.com.sg
Website: <http://www.land-equipment.com.sg>

AKK1610